



CE LY31-01030

DESCRIPTION:

LAMBARIO-MS04-1200W-IP20-MOTION SENSOR

Welcome to use LY31-01030 Infrared motion sensor!

This product adopts high sensitivity detector, integrate circuit and SMT; It gathers automatic, convenient, safe, energy-saving, practical functions; It has wide detection range made up of up and down, left and right service field; It utilizes human motion infrared rays as control signal sources, when one enters the detection field, it will start the controlled load at once; It can identify day and night automatically; It is easy to install and its usage is wide; It has the function of power indication and detection indication.

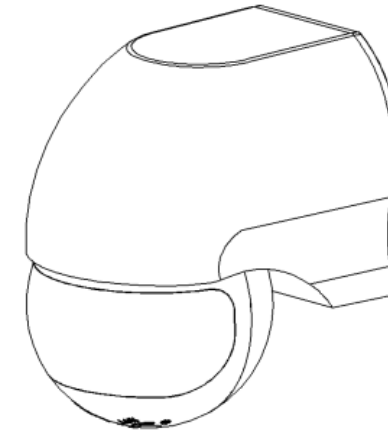

SPECIFICATION:

Power Source: 220V/AC-240V/AC

Power Frequency: 50Hz

Ambient Light: 3-2000LUX (adjustable)

Time-Delay: min: 10sec±3sec
Max: 7min±2min

Rated Load: 1200W (incandescent lamp)
300W (energy-saving lamp)

Detection Distance: 12m max (<24°C)

Detection Range: 180°

Working Temperature: -20~+40°C

Working Humidity: <93%RH

Installation Height: 1.8m~2.5m

Power Consumption: 0.45W (work)
0.1W (static)

Detection Moving Speed: 0.6~1.5m/s

FUNCTION:

- Detection field: The wide detection range is made up of up and down, left and right, the detection range could be adjusted according to your desire, but the moving orientation in detection field has great relation with the sensitivity.
- Identify day and night automatically: The ambient light of ST12 could be adjusted according to your desire: when turn to SUN (max), it will work day and night, when turn it to MOON (min), it will only work in the ambient light less than 3LUX. As for adjustment, please refer to testing way.
- Time-delay is added continually: When it receives the second induction signals after the first induction, it will compute time once more on the rest of the first time-delay basis (set time).
- Time-delay is adjustable: It can be set according to your desire, the minimum is 10sec±3sec, and the maximum is 7min±2min.

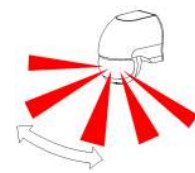

Good sensitivity

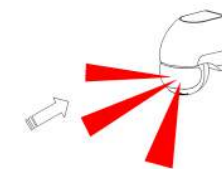
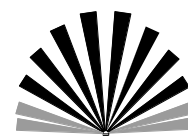

Poor sensitivity

INSTALLATION: (see the diagram)

- Shut off power.
- Loosen the screw on the bottom lid, open the wiring terminal, pass the wire of power and load through the bottom lid.
- Fix the bottom lid with inflated screw on the selected position.
- Connect the power and load wire into connection-wire column according to the connecting figure.
- Put the sensor on the bottom lid, twist the screw tightly then electrify it and test it.

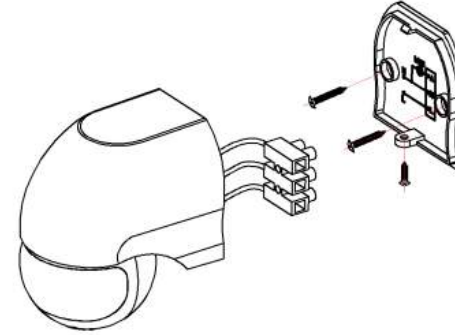

CONNECT-WIRE FIGURE:

(See the right figure)

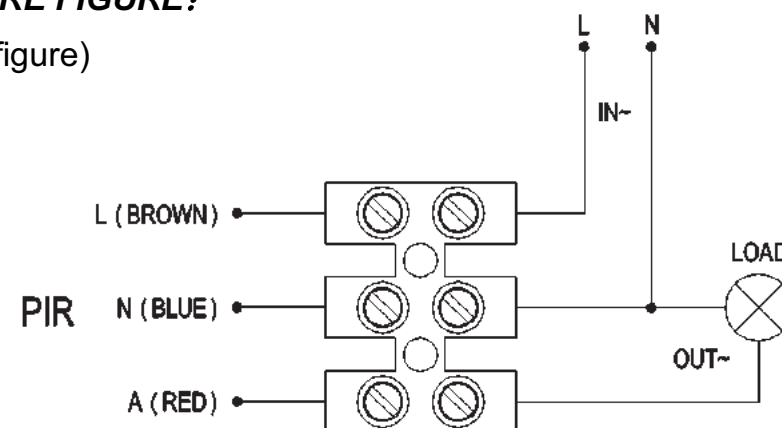

TEST:

- Turn time knob anti-clockwise to the minimum; turn the LUX knob clockwise to the maximum (SUN), Switch on power, the controlled load should not work, needing to preheat within 5-30sec.
- The sensor will be sensed again in 5-10sec later when the first induction is finished; the load should work when received sensor signal and stop working within 7-13sec with no any sensor signal.
- Turn LUX knob to minimum anti-clockwise, if you test it when the ambient light is more than 3LUX, the induction load would not work after the load stops working; the load should work if you cover the detection window with opaque object (towel etc),it would be regular the load stops to work within 7-13sec under no induction signal condition.

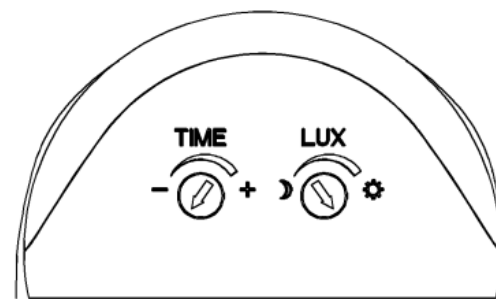

Note: when testing in daylight, please turn LUX knob to  (SUN) position, otherwise the

sensor lamp could not work!

NOTE:

- Should be installed by electrician or experienced person.
- Avoid installing it on the unrest object.
- There should be no hindrance and moving objects in front of the detection windows to effect detection.
- Avoid installing it near air temperature alteration zones such as air condition, central heating, etc.
- Considering your safety, please do not open the cover when you find the hitch after installation.
- If there is difference between instruction and the function the product has, please give priority to product and sorry not to inform you additionally.

SOME PROBLEM AND SOLVED WAY:

- The load do not work:
 - a. please check if the connection-wiring of power and load is correct.
 - b. please check if the load is good .
 - c. please check if the working light set correspond to ambient light.
- The sensitivity is poor:
 - a. Please check if there has hindered in front of the detection window to effect to receive the signal.
 - b. Please check if the ambient temperature is too high.
 - c. Please check if the induction signal source is in the detection fields.
 - d. Please check if the installation height corresponds to the height showed in the instruction.
 - e. Please check if the moving orientation is correct.
- The sensor can not shut off the load automatically:
 - a. Please check if there is continual signal in the detection field.
 - b. Please check if the time delay is the longest.
 - c. Please check if the power corresponds to the instruction.
 - d. Please check if the temperature near the sensor changes obviously, such as air condition or central heating etc.